



**Standard Burner Systems:**

- PB-\*\*(P)A
- PB\*\*-01(M)(P)
- PB\*\*-11(M)(P)
- PB\*\*-15(M)(P)
- PB\*\*-17(M)(P)

**\*\*Sizes:  
(18, 24, 30)**



**DESIGN CERTIFIED  
to  
Vented Decorative Appliance  
ANSI Z21.60b-2004  
CSA 2.26b-2004**

**FOR INSTALLATION IN  
SOLID-FUEL BURNING  
FIREPLACES\***

**FOR USE WITH  
FYRE GLASS / FYRE GEMS**

**PB SERIES VENTED GAS BURNER SYSTEMS (REGULATED)**

**WARNING**

**If the information in this manual is not followed exactly, a fire or explosion may result, causing property damage, personal injury, or loss of life.**

**Do not store or use gasoline or other flammable vapors and liquids in the vicinity of this or any other appliance.**

**WHAT TO DO IF YOU SMELL GAS:**

- Open a window.
- Do not try to light any appliance.
- Do not touch any electrical switch; do not use any phone in the building.
- Immediately call the gas supplier from a neighbor's phone. Follow gas supplier's instructions.
- If you cannot reach the gas supplier, call the fire department.

**Installation and service must be performed by a qualified professional installer, service agency, or the gas supplier.**

**This appliance is only for use with the type of gas indicated on the rating plate.**

**IMPORTANT: READ THESE INSTRUCTIONS CAREFULLY BEFORE STARTING INSTALLATION OF THE SYSTEM**

The Real-Fyre gas burner system is to be installed only in a solid-fuel burning fireplace with a working flue and constructed of noncombustible material. The installation, including provisions for combustion and ventilation air must conform with the *National Fuel Gas Code, ANSI Z223.1/NFPA 54*, or the *CSA B149.1, Natural Gas and Propane Installation Code*, and applicable local building codes.

A damper clamp is included to maintain the minimum permanent vent opening and to prevent full closure of the damper blade. **The chimney damper MUST be fully opened when burning the burner system. The burner system is designed to burn with yellow flames; thus adequate ventilation is absolutely necessary.**

To comply with certification, listings, and building code acceptances, and for safe operation and proper performance of this burner system, use ONLY Peterson parts and accessories. Use of other controls, parts, and accessories that are not designed for use with Real-Fyre gas burner systems is prohibited and will void all warranties, certifications, listings, and building code approvals, and may cause property damage, personal injury, or loss of life.



**INSTALLER:  
Leave this manual with the appliance.  
CONSUMER:  
Retain this manual for future reference.**



**Systèmes standard de brûleur:**

PB-\*\*(P)A  
PB-\*\*-01(M)(P)  
PB-\*\*-11(M)(P)  
PB-\*\*-15(M)(P)  
PB-\*\*-17(M)(P)

\*\*Sizes:  
(18, 24, 30)



**CONCEPTION CERTIFIÉE**

à

Vented Decorative Appliance  
ANSI Z21.60b-2004  
CSA 2.26b-2004

**POUR L'INSTALLATION EN  
CHEMINÉES BRÛLANTES DE  
COMBUSTIBLE SOLIDE\***

**POUR L'USAGE AVEC  
VERRE/GEMMES**

**SYSTÈMES EXHALÉS PAR SÉRIE DE BRÛLEUR À GAZ DE PB (RÉGLÉS)**

**AVERTISSEMENT**

Si l'information en ce manuel n'est pas suivie exactement, une incendie ou une explosion peut résulter, entraînant des dégâts matériels,

Ne stockez pas ou n'employez pas l'essence ou d'autres vapeurs et liquides inflammables à proximité de ceci ou d'aucun autre appareil.

**CE QUI À FAIRE SI VOUS SENTEZ LE GAZ:**

- Ouvrez une fenêtre.
- N'essayez pas de n'allumer aucun appareil.
- Ne touchez aucun commutateur électrique; n'utilisez aucun téléphone dans le bâtiment.
- Appelez immédiatement le fournisseur de gaz du téléphone du voisin. Suivez les instructions du fournisseur de gaz.
- Si vous ne pouvez pas atteindre le fournisseur de gaz, appelez le

L'installation et le service doivent être assurés par un installateur qualifié et professionnel, l'agence de service, ou le fournisseur de gaz.

Cet appareil sert seulement avec le type de gaz indiqué de la plaque de contrôle.

**INSTALLATEUR :**

Laissez ce manuel avec l'appareil.

**CONSOMMATEUR:**

Maintenez ce manuel pour la future référence.

**IMPORTANT: LISEZ CES INSTRUCTIONS  
SOIGNEUSEMENT AVANT DE  
COMMENCER L'INSTALLATION DU  
SYSTÈME.**

Le Vrai-Fyre système de brûleur à gaz doit être installée seulement dans une cheminée brûlante de combustible solide avec une conduite de cheminée fonctionnante et être construit avec du matériel non-combustible. L'installation, y compris des dispositions pour l'air de combustion et de ventilation doit se conformer au code national de gaz de carburant, la norme ANSI Z223.1/ NFPA 54, ou le CSA B149.1, code d'installation de gaz naturel et de propane, et codes du bâtiment locaux applicables.

Une bride plus humide est incluse pour maintenir l'ouverture permanente minimum de passage et pour empêcher la pleine fermeture de la lame plus humide. L'amortisseur de cheminée DOIT être entièrement ouvert en brûlant le système de brûleur. Le système de brûleur est conçu pour brûler avec les flammes jaunes ; ainsi à ventilation proportionnée est absolument nécessaire.

Pour se conformer à la certification, les listes, et les acceptations de codes du bâtiment, et pour l'exploitation sûre et l'exécution appropriée de ce système de brûleur, utilisent SEULEMENT des pièces et des accessoires de Peterson. L'utilisation d'autres commandes, pièces, et accessoires qui ne sont pas conçus pour l'usage avec de Vrais-Fyre systèmes de brûleur à gaz est interdite et videra toutes les garanties, certifications, listes, et approbations de codes du bâtiment, et peut causer des dégâts matériels, le dommage corporel, ou des pertes humaines.

\***Note:** Des Plein-carburants ne seront pas brûlés dans une cheminée où un appareil



## TABLE OF CONTENTS

|    |  |
|----|--|
| 4  | PARTS LIST   |
| 5  | IMPORTANT INFORMATION                                      |
| 6  | GLASS / GEMS QUANTITY DETERMINATION                        |
| 7  | INSTALLATION   |
| 7  | INSTALLING THE BURNER                                      |
| 8  | 01 VALVE MODELS ONLY                                       |
| 8  | INSTALLING OR REPLACING BATTERIES FOR IGNITION MODULE PACK |
| 8  | SWITCH BOX PLACEMENT                                       |
| 8  | CONNECTING THE IGNITION PACK TO THE VALVE                  |
| 9  | GLASS / GEMS PLACEMENT                                     |
| 9  | BURNER PREPARATION   |
| 11 | LIGHTING INSTRUCTIONS - MANUAL PILOT AND SERIES 17 VALVE   |
| 13 | LIGHTING INSTRUCTIONS - SERIES 11 VALVE                    |
| 15 | LIGHTING INSTRUCTIONS - SERIES 15 VALVE                    |
| 17 | LIGHTING INSTRUCTIONS - SERIES 01 VALVE                    |
| 18 | CLEANING AND MAINTENANCE                                   |
| 18 | MAINTENANCE  |
| 18 | CLEANING   |
| 18 | SERVICE  |
| 18 | FLAME DESCRIPTION  |
| 19 | PILOT BURNER ADJUSTMENT (IF EQUIPPED)                      |
| 20 | TROUBLESHOOTING  |
| 22 | WARRANTY   |

# PARTS LIST

Before installation, check that your gas burner system is complete. See the PARTS LIST below. If any parts are missing or damaged, contact your Real-Fyre® dealer before installing or using the burner. Be sure you know the model and size of your set when ordering options or replacement parts and

**Fig. 4-1**

See your local dealer for replacement parts.

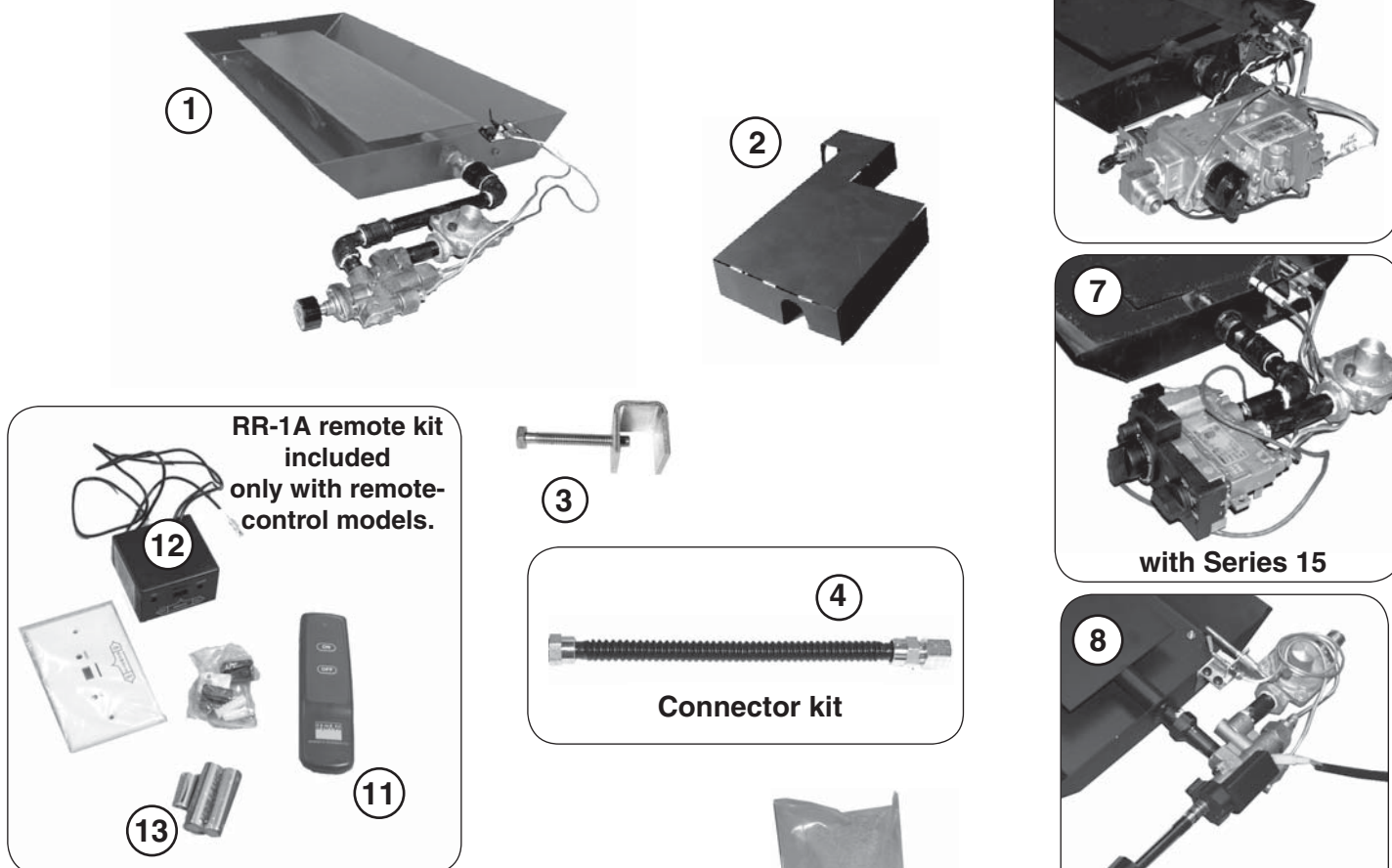

All drawings & photos in this manual are not to scale.

| ITEM No. | DESCRIPTION   | QTY |
|----------|---|-----|
| 1.       | Burner pan  | 1   |
| 2.       | Heat shield   | 1   |
| 3.       | Damper clamp with bolt  | 1   |
| 4.       | Connector kit (with adapter)  | 1   |
| 5.       | Select sand granules (nat. only) or vermiculite granules (propane only) | 1   |
| 6.       | Series 11 valve   |     |
| or 7.    | Series 15 valve   |     |
| or 8.    | Series 17 valve   |     |
| or 9.    | Series 01 valve   |     |
| or 10.   | Series 26 (manual) valve  |     |
| 11.      | *Remote control (optional)  | 1   |
| 12.      | *Remote receiver (optional)   | 1   |
| 13.      | *Batteries (optional)   | 3   |

\*not included with manual systems identified with an "M" in the part number.

Glass / gems are purchased and packaged separately. Quantity will vary, depending on selection. Glass and gems are available in various colors; contact



## IMPORTANT INFORMATION

Do not use this burner system if any part has been underwater. Immediately call a qualified professional service technician to inspect the appliance and to replace any part of the control system and any gas control which has been underwater.

The gas burner system must be isolated from the gas supply piping system by closing its individual shut-off valve during any pressure testing of the gas supply system at test pressures equal to or less than 1/2 psig. The gas burner system and its individual shut-off valve must be disconnected from the gas supply piping system when testing at pressures in excess of 1/2 psig.

Keep the area of the gas burner system clear and free from combustible materials, gasoline, and other flammable vapors and liquids.

| Burner size | Min. Fireplace Dimensions |       |        | BTU  |     |
|-------------|---------------------------|-------|--------|------|-----|
|             | Width*                    | Depth | Height |      |     |
| 18"         | 28"                       | 16"   | 18"    | 75k  | 60k |
| 24"         | 34"                       | 16"   | 18"    | 90k  | 75k |
| 30"         | 40"                       | 16"   | 18"    | 110k | 90k |

\* This required width allows for centering of the system.

**Important:** For safe operation and proper performance and to comply with CSA Certification, ONLY Robert H. Peterson parts and accessories must be used with this gas burner system.

The minimum inlet gas supply pressure for purpose of input adjustment is 5" for natural gas and 11" for propane gas. Maximum inlet gas supply pressure for this burner is 10.5" for natural and 13" for propane gas.

Gas supply pipe must be 1/2" minimum interior diameter or larger. If the gas line is longer than 20', a larger diameter line may be necessary.

**A fireplace screen must be in place when the system is burning.** Provisions for adequate combustion air must be maintained. Unless other provisions for combustion air are provided, the screen shall have an opening(s) for introduction of combustion air. Combustion air is adequate when all flames curl into the fireplace and away from the screen. **When a glass fireplace enclosure (door) is used, leave the doors fully open when the system is in operation.**

The minimum firebox dimensions in which the burner system is certified to be installed, is listed in the Technical Data Table here.

**Note:** For remote ready units, the maximum

| Minimum Free Opening Area of Chimney Damper for Venting (sq. in.) |                              |     |     |                              |     |     |
|---|------------------------------|-----|-----|------------------------------|-----|-----|
|   | For Factory-Built Fireplaces |     |     | For Masonry-Built Fireplaces |     |     |
| Chimney   | 18"                          | 24" | 30" | 18"                          | 24" | 30" |
| 15' (min.)  | 46                           | 56  | 69  | 50                           | 60  | 73  |
| 20'   | 42                           | 50  | 61  | 46                           | 54  | 65  |
| 25'   | 40                           | 48  | 58  | -                            | -   | -   |
| 30'   | 37                           | 45  | 55  | 41                           | 49  | 59  |

**Note:** The minimum chimney height from hearth to top of chimney is 15'.

### IMPORTANT

For all valves, the air **MUST** be purged from the gas line before the pilot will light and burn properly. The time needed to purge will depend on the length of the gas line to the unit and the amount of time since the unit or gas line was last used. It may take several minutes before all the air is purged and the pilot will light and burn properly. Follow the LIGHTING INSTRUCTIONS section in this manual.

## GLASS / GEMS QUANTITY DETERMINATION

**CAUTION:** Sand granules are for use with natural gas systems only. Always use vermiculite granules for propane gas systems.

The granules that come with the burner system are pre-measured and must be used per these instructions (see GLASS / GEMS PLACEMENT section).

Decorative glass / gems (purchased separately) must be placed to cover the burner (but not on the valve or pilot, if equipped). See Table 6-1 for the minimum bag requirement depending on your burner size. Additional glass / gems may be purchased and placed around the burner if desired.

Should you wish to fill the entire fireplace floor with glass / gems; instead use Table 6-2 to determine how many bags of glass / gems to order **based on fireplace size**.

One 10-lb. bag of glass / gems fills approximately 144 cubic inches.

**CAUTION:** When covering the burner with glass / gems; do not exceed 1" above the top of the burner. Additional glass / gems directly on top of the burner may result in unsafe ignition.

| Minimum burner coverage requirement<br>Table 6-1 | Burner size |    |    |
|--|-------------|----|----|
|  | 18          | 24 | 30 |
| Glass / gem<br>10 lb. bag(s) needed              | 1           | 1  | 1  |

- OR -

| Fireplace complete coverage<br>Table 6-2 | Fireplace    |                    |                           |                | Glass / gems<br>10 lb. bags needed<br>for 2" depth |
|--|--------------|--------------------|---------------------------|----------------|--|
|  | Opening size | Center width (in.) | Front to back depth (in.) | Area (sq. in.) |  |
| <b>Standard<br/>Fireplace Sizes</b>      | 28"          | 25                 | 16                        | 400            | 6  |
|  |              |                    |                           | 540            | 8  |
|  | 36"          | 30                 | 23                        | 690            | 10   |
|  | 32" see-thru | 31                 | 23                        | 713            | 10   |
|  | 42"          | 36                 | 30                        | 828            | 12   |
|  |              |                    |                           | 1085           | 15   |
|  | 50"          | 46                 | 33                        | 1334           | 19   |

These bag quantities listed allow for an approximate 2" depth of glass / gems in the entire fireplace floor, without a burner. (The volume of the burner will take up some space, allowing for some excess glass to be used as desired, or stored as extra for later use.)

Your fireplace area can be determined by measuring the center width of your fireplace in inches and multiplying by the depth from front to back in inches. You can then use the area column in the table above to approximate the number of bags needed.

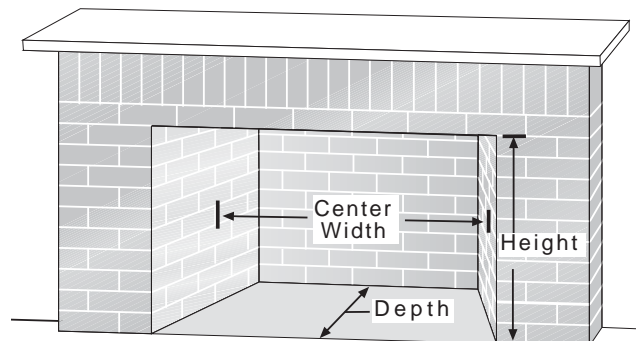

# INSTALLATION

The damper clamp with hex bolt (Fig. 7-1) is provided as a means to prevent full closure of the damper blade. The clamp is easily attached to most damper blades with pliers or a wrench, and must be permanently installed. The clamp is designed to prevent accidental closure of the damper when installed as illustrated (Fig. 7-2 and Fig. 7-3). Should the clamp not fit, or fail to provide the permanent vent opening listed in the table found above, have a permanent stop installed, remove the damper blade, or have the damper cut to provide the minimum permanent opening required.

**Note:** These are minimum damper opening specifications. The damper must be completely opened when operating this gas appliance to achieve the best ventilation possible.

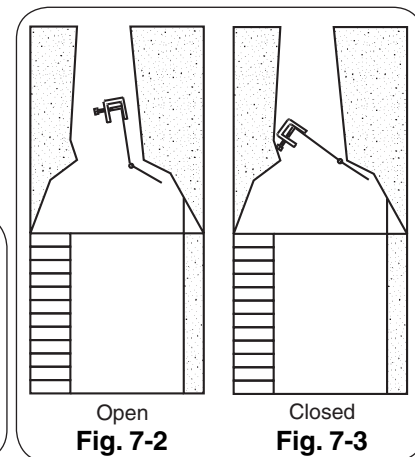
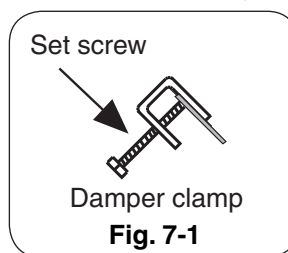

## INSTALLING THE BURNER

The Real-Fyre gas burner system must be installed by a qualified professional service technician. Instructions must be followed carefully to ensure proper performance and full benefit from the gas burner system. **Check to be sure the burner system is designed and labeled for the type of gas (natural or propane gas) supplied to the fireplace. Fireplace floor must be level, clean, and smooth.**

**WARNING:** Failure to position the parts in accordance with these diagrams or failure to use only parts specifically approved with this appliance may result in property damage or personal injury.

REFER TO THE PARTS LIST WHEN FOLLOWING THESE INSTRUCTIONS.

1. MAKE SURE THE FIREPLACE GAS SUPPLY IS TURNED OFF.
2. Locate the gas-supply stub inside the fireplace and remove the cap, if attached (see Fig. 7-4).

**CAUTION:** When removing the cap, make sure the stub does not turn, loosening the connection inside the wall.

3. Attach the nut end of the flex connector (Item 4) to the adapter found on the valve or, if attached, on the regulator behind the valve. Tighten securely.
4. Place the burner system into the fireplace so that it is centered.
5. **Be sure gas to the fireplace is off.** Attach the large adapter end of the flex connector (Item 4) to the gas-supply stub using a pipe compound resistant to all gases. Ensure adapter (and nut) are tightened securely. Ensure the pan rests level on the fireplace floor after connection. Adjust the pan if necessary.
6. **LEAK TEST:** Turn on the fireplace gas supply, and test at all connections for leaks using the appropriate soapy water solution. If bubbles appear, a leak is present. Turn off the gas and tighten at all connections. Repeat until no leaks are present. If a leak persists, turn off the gas supply and contact the local gas company or dealer. **NEVER USE A FLAME TO CHECK FOR LEAKS.**

Turn off the gas supply prior to proceeding.

7. Place the heatshield over the regulator and/or valve.

**Important:** Heatshields must be in place during operation of the gas burner system. Overheating of the valve will cause shut down of the gas burner system or other operating problems.

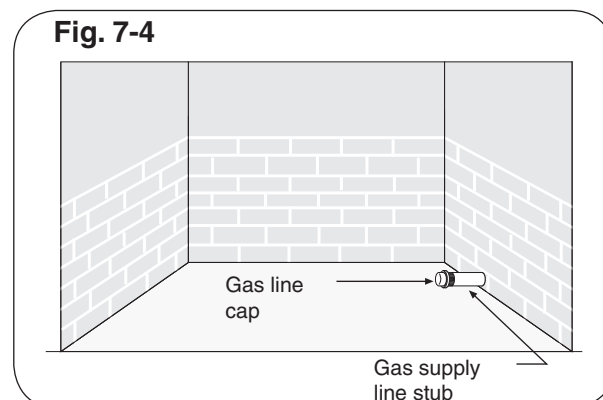

# 01 VALVE MODELS ONLY

## CONNECTING THE IGNITION PACK TO THE VALVE

The 01 valve comes complete with the wiring harness connected to the switch box. You may wish to ensure it is correctly connected before finally connecting the three wires to the valve, as below.

### TO CHECK THE WIRING ASSEMBLY:

- A. Check that the wiring harness is fitted tightly into the connector on the green ignitor pack inside the switch box (Fig. 8-1).
- B. Check that the female connectors on the two black wires from the pilot assembly (wires marked "I" and "S") are inserted fully into the male connectors on the ignitor pack (Fig. 8-2).
- C. Check the connection of the red and black wires of the wire harness to the respective counterpart wires from the battery holder (red-red and black-black). The two brown wires should be connected to the switch.

**Note:** The two spare brown wires with coated male connectors are used to connect a remote system (if equipped).

- D. Connect the wires to the valve in the following order (see Fig. 8-2):

**Orange** wire marked **THTP** - to **THTP** connector on valve

**Black** wire marked **TP** - to **TP** connector on valve

**Green** wire marked **TH** - to **TH** connector on valve

The diagram below shows the wiring layout for the complete unit.

## INSTALLING OR REPLACING BATTERIES FOR IGNITION MODULE PACK

Two 1.5-volt (D-cell) alkaline batteries are supplied with the burner system. To install or replace batteries, remove any old batteries (if applicable) and install new batteries according to the diagram illustrated on the battery holder mounted inside the switch box (Fig. 8-3).

**Note:** For the system to work properly, it is suggested that you replace the batteries annually with fresh batteries. Always replace all the batteries at the same time.

## SWITCH BOX PLACEMENT

The switch box is aesthetically designed and is an integral part of the operation of the 01 valve.

Place the switch box a minimum of 6" from the burner/flame. Additionally, if the switch box is in the firebox, the rear of the switch box must not be exposed to the flame. Set the box on its side and face the bottom of the box toward the right firebox wall. Be sure that the pilot and valve wire bundles remain clear of the burner, valve, and heat shield at all times.

**Note:**  
Coil excess wire within the switch box.

**CAUTION:**  
**THE SWITCH BOX MAY BE HOT DURING AND AFTER OPERATION.**

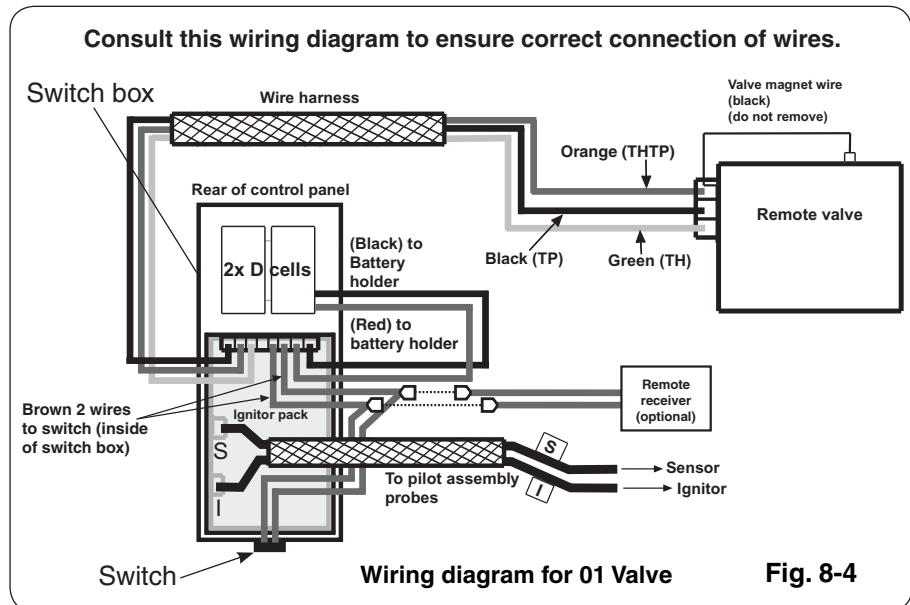
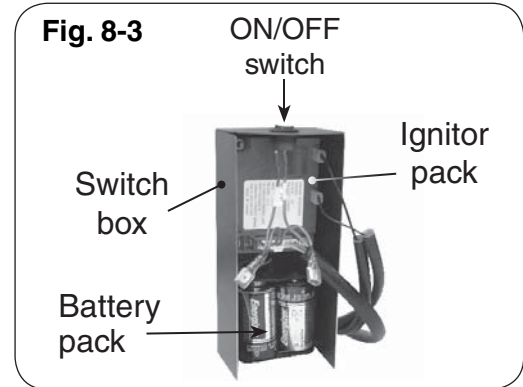
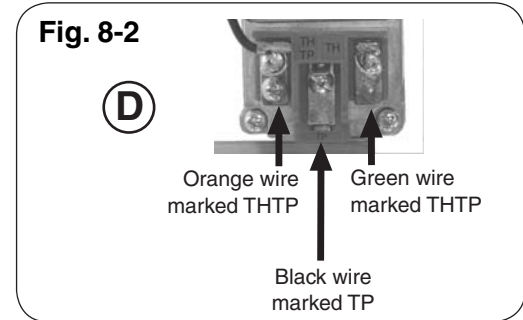
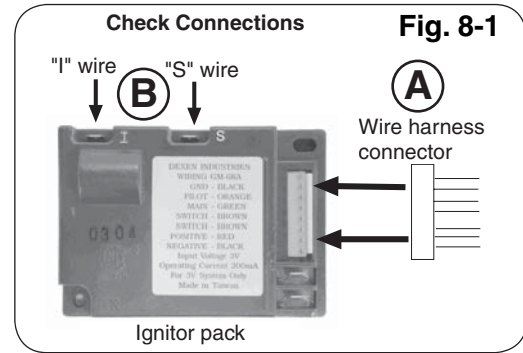



## GLASS / GEMS PLACEMENT

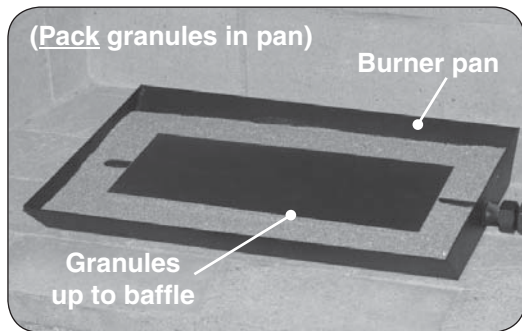

Fig. 9-1

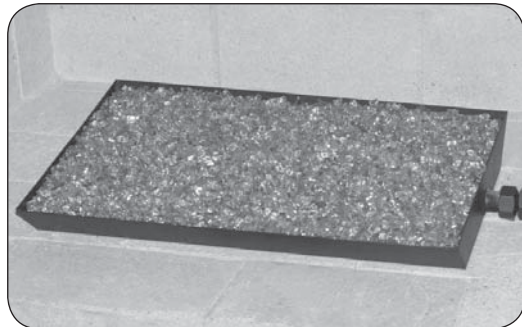

Fig. 9-2



Fig. 9-3

### BURNER PREPARATION

After hooking up the burner to the fireplace gas supply and placing the heat shield on the valve assembly (if applicable), the decorative media (granules and glass / gems) must be added for the burner to function as designed.

**Note:** Installation is the same for glass and gems. Glass shown here. These instructions show sand granules being used as a base for the glass, but only natural-gas burners use sand. For propane burners, follow these instructions using vermiculite.

### WARNING

The burner and pilot (if equipped) must be **OFF** (fully extinguished), and all valve covers must be in place before pouring media onto the burner. It may also be necessary to temporarily cover the pilot assembly (if equipped) to keep media out of it during this procedure.

### GRANULE PLACEMENT

Pour the granules into the pan, just below level of the center flame baffle. Then pack the granules into the pan. Add additional granules as needed (see Fig. 9-1).

### GLASS / GEMS PLACEMENT

**CAUTION:** Glass pieces may have sharp edges. Be careful handling the glass. Use hand protection, such as gloves, if necessary.

1. Pour the glass / gems directly on top of the burner pan so that the burner pan is covered completely and evenly (see Fig. 9-2). DO NOT exceed a 1" depth of glass directly above the burner pan.

**Note:** At this stage the burner will function as designed; however, more glass / gems may be added around the burner for decorative purposes.

2. Add additional glass / gems around the burner pan as desired (Fig. 9-3).

# INSTRUCTIONS D'ÉCLAIRAGE - PILOTE ET VALVE MANUELS DE LA SÉRIE 17

## POUR VOTRE SÛRETÉ, LISEZ AVANT DE S'ALLUMER

**AVERTISSEMENT:** Si vous ne suivez pas ces instructions exactement, un incendie ou une explosion peut résulter entraînant des dégâts matériels, des blessures ou la perte de la vie.

N'employez pas cet appareil si n'importe quelle partie a été sous-marine. Réclamez immédiatement un technicien de service professionnel qualifié et pour inspecter l'appareil et pour remplacer n'importe quelle partie du système de commande et de n'importe quelle commande de gaz qui a été sous l'eau.

Le Vrai-Fyre système de brûleur a un pilote qui peut être allumé à la main en utilisant une allumette ou un allumeur. En allumant le pilote, suivez ces instructions exactement.

AVANT DE S'ALLUMER, sentez tous autour du secteur de brûleur pour le gaz. Soyez sûr de sentir à côté du plancher car un certain gaz est plus lourd que l'air et arrangez sur le plancher. SI VOUS SENTEZ LE GAZ, SUIVEZ LES INSTRUCTIONS À LA P. 1.

Utilisez seulement votre main pour enfoncer ou pour tourner le bouton de commande de gaz. N'utilisez jamais les outils. Si le bouton n'enfoncera pas ou ne tournera pas à la main, n'essayez pas de le réparer. Appelez un technicien de service professionnel qualifié et. La force ou la réparation essayée peut avoir comme conséquence l'incendie ou l'explosion.

### ALLUMER LE PILOTE

1. Si le bouton de soupape de commande de brûleur n'est pas dans la position de **OFF**, enfoncez la poignée de commande de gaz légèrement et tournez-vous dans le sens des aiguilles d'une montre  vers **OFF** (fig. 10-1).

**Note:** Le bouton de commande de brûleur ne peut pas être tourné du **PILOT** au **OFF** à moins que la poignée soit enfoncée légèrement. Ne forcez pas.

Attendez cinq minutes pour dégager dehors n'importe quel gaz. Si vous sentez alors le gaz, **ARRÊTEZ!** Informez votre fournisseur de gaz ou le département de feu immédiatement. Si vous ne sentez pas le gaz, passez dessus à l'étape 2.

2. Tournez le bouton de commande de brûleur dans le sens contraire des aiguilles d'une montre  au **PILOT** (fig. 10-1). Poussez la poignée de commande toute la manière dedans et tenez-la. Tenez une longue allumette de cheminée ou un proche plus léger le thermocouple pour allumer le pilote. Continuez à tenir le bouton de commande pour approximativement 30 secondes après que le pilote est allumé pour permettre au thermocouple de détecter la flamme pilote, puis libérez le bouton. Le pilote restera s'est allumé.

- Si le pilote ne s'allumera pas, répétez les étapes 1. et 2.
- Si le pilote ne restera pas s'allumait après que plusieurs essais, tournent la poignée de commande de gaz à **OFF** et appellent votre fournisseur de technicien ou de gaz de service.

### ALLUMAGE DU BRÛLEUR PRINCIPAL

1. Assurez-vous que le pilote brûle.
2. Tournez la poignée de commande de gaz dans le sens contraire des aiguilles d'une montre  à **ON** (fig. 10-1) pour mettre à feu le brûleur. Le brûleur mettra à feu.

**Note:** Examinez périodiquement la flamme pilote pour assurer le modèle approprié de flamme (Fig. 10-1).

### ASSUREZ-VOUS QUE LE THERMOCOUPLE ET L'ASSEMBLÉE PILOTE SONT EN ALIGNEMENT CORRECT AVEC L'UN L'AUTRE (FIG. 10-1).

### ROTATION OUTRE DU BRÛLEUR PRINCIPAL

1. De la position de **ON**, tournez le bouton de commande dans le sens des aiguilles d'une montre  à la position **PILOT**. Le brûleur s'éteindra et le pilote restera s'est allumé.

### S'ÉTEINDRE LE PILOTE

1. Si complet l'arrêt est désiré, de la position **PILOT**, de l'enfoncer le bouton de commande légèrement et du tour dans le sens des aiguilles d'une montre  à la position de repos. Ne forcez pas le bouton. **NE FORCEZ PAS LE BOUTON.** Ceci exigera du pilote d'être re-s'est allumé avant d'utiliser le brûleur encore.

**Le SPK-17 est capable de l'éclairage à distance. Si votre unité est équipée d'un extérieur, lisez et suivez les instructions à distance séparées d'actionner le brûleur à distance.**

(valve manuelle montrée)



1. S'ALLUMER - tournez le bouton de commande de brûleur à **OFF**  et attendez 5 minutes avant de s'allumer.

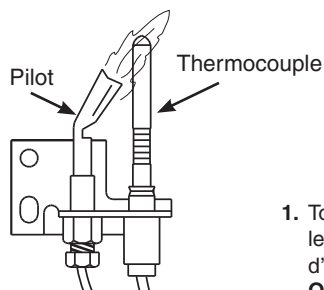
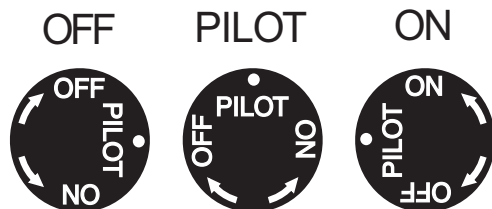



Fig. 10-1



1. Tournez le cadran dans le sens des aiguilles d'une montre  à **OFF** seulement quand l'arrêt complet est nécessaire.
2. Tournez le cadran dans le sens contraire des aiguilles d'une montre  à la position **PILOT**. Avec le bouton prêt de pression d'allumette dedans et la prise pendant 60 secondes tout en allumant le pilote.
3. Tournez le bouton contre- dans le sens des aiguilles d'une montre à **ON** au brûleur léger.

# LIGHTING INSTRUCTIONS - MANUAL PILOT AND SERIES 17 VALVE

## FOR YOUR SAFETY, READ BEFORE LIGHTING

### WARNING

If you do not follow these instructions exactly, a fire or explosion may result, causing property damage, personal injury, or loss of life.

Do not use this appliance if any part has been underwater. Immediately call for a qualified professional service technician to inspect the appliance and to replace any part of the control system and any gas control that has been underwater.

The Real-Fyre® burner system has a pilot that can be lit by hand using a match or lighter. When lighting the pilot, follow these instructions exactly.

**BEFORE LIGHTING**, smell all around the burner area for gas. Be sure to smell next to the floor, as some gas is heavier than air and will settle on the floor. **IF YOU SMELL GAS, FOLLOW THE INSTRUCTIONS ON P. 1.**

Use only your hand to push in or turn the gas control knob. Never use tools. If the knob will not push in or turn by hand, don't try to repair it. Call a qualified professional service technician. Excessive force or attempted repair may result in fire or explosion.

### LIGHTING THE PILOT

1. Push in the gas control knob slightly and turn clockwise ↻ to **OFF** (Fig. 11-1). Refer to the PARTS LIST for the location of the burner control valve knob.

**Note:** The burner control knob cannot be turned from **PILOT** to **OFF** unless the knob is pushed in slightly. Do not force.

Wait five minutes to clear out any gas. If you then smell gas, **STOP!** Notify your gas supplier or the fire department immediately. If you don't smell gas, go on to step 2.

2. Turn the burner control knob counter-clockwise ↺ to **PILOT** (Fig. 11-1). Push the control knob **firmly and fully** in and hold. Hold a long fireplace match or lighter near the thermocouple to light the pilot. Continue to hold the control knob in for approximately 30 seconds after the pilot is lit, then release the knob. The pilot will remain lit.
- If the pilot will not light, repeat steps 1 and 2.
  - If the pilot will not stay lit after several tries, turn the gas control knob to **OFF** and call your service technician or gas supplier.

### IGNITING THE MAIN BURNER

1. Make sure the pilot is burning.
2. Turn the gas control knob counterclockwise ↺ to **ON** (Fig. 11-1) to ignite the burner. The burner will ignite.

**Note:** Periodically check the pilot flame for the proper flame pattern (Fig. 11-1).

**MAKE SURE THE THERMOCOUPLE AND PILOT ASSEMBLY ARE IN CORRECT ALIGNMENT WITH EACH OTHER (Fig. 11-1).**

### TURNING OFF THE MAIN BURNER

1. From the **ON** position, turn the control knob clockwise ↻ to the **PILOT** position. The burner will extinguish, and the pilot will remain lit.

### EXTINGUISHING THE PILOT

1. If complete shutdown is desired, from the **PILOT** position, push in the control knob slightly and turn clockwise ↻ to the **OFF** position. **Do not force the knob.** This will require the pilot to be relit before using the burner again.

The series 17 valve is capable of remote operation. **If this unit was shipped with a remote, or if a remote system was installed later, read and follow the separate remote instructions to operate the burner remotely.**

(Manual valve shown)



1. Lighting - Turn the burner control knob to **OFF** ↻ and wait 5 minutes before lighting.

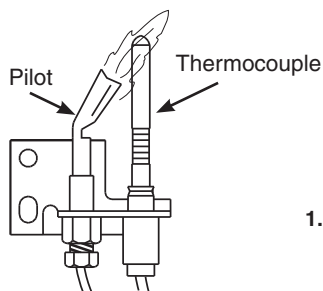

**Pilot Assembly**  
**Fig. 11-1**

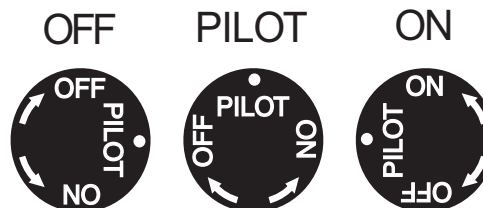

1. Turn the knob clockwise ↻ to **OFF** only when complete shutdown is desired or prior to lighting the pilot.
2. Turn knob counterclockwise ↺ to **PILOT** position. With match ready, press knob in and hold for 60 seconds while lighting pilot.
3. Turn the knob counterclockwise ↺ to **ON** to light the burner.

# INSTRUCTIONS D'ÉCLAIRAGE - VALVE DE LA SÉRIE 11

## POUR VOTRE SÛRETÉ, LISEZ AVANT DE S'ALLUMER

**AVERTISSEMENT :** Si vous ne suivez pas ces instructions exactement, un incendie ou une explosion peut résulter entraînant des dégâts matériels, des blessures ou la perte de la vie.

N'employez pas cet appareil si n'importe quelle partie a été sous-marine. Réclamez immédiatement un technicien de service professionnel qualifié et pour inspecter l'appareil et pour remplacer n'importe quelle partie du système de commande et de n'importe quelle commande de gaz qui a été sous l'eau.

Le Vrai-Fyre système de brûleur a un pilote qui peut être allumé à la main en utilisant une allumette ou un allumeur. En allumant le pilote, suivez ces instructions exactement.

AVANT DE S'ALLUMER, sentez tous autour du secteur de brûleur pour le gaz. Soyez sûr de sentir à côté du plancher car un certain gaz est plus lourd que l'air et arrangez sur le plancher. SI VOUS SENTEZ LE GAZ, SUIVEZ LES INSTRUCTIONS À LA P. 1.

Utilisez seulement votre main pour enfoncer ou pour tourner le bouton de commande de gaz. N'utilisez jamais les outils. Si le bouton n'enfoncera pas ou ne tournera pas à la main, n'essayez pas de le réparer. Appelez un technicien de service professionnel qualifié et. La force ou la réparation essayée peut avoir comme conséquence l'incendie ou l'explosion.

### ALLUMANT LE PILOTE

Pour lire le bouton de commande de soupape de sûreté (Fig. 12-1) lisez l'indicateur formé par l'anneau la plus proche en métal d'inscription.

1. Si le bouton de commande de soupape de sûreté est en position **PILOT**, enfoncez légèrement sur le bouton et tournez-le dans le sens des aiguilles d'une montre jusqu'à la position de **OFF**.
2. Libérez le bouton et attendez cinq minutes.
3. Tournez le bouton de soupape de sûreté dans le sens contraire des aiguilles d'une montre à la position **PILOT** (seulement le gaz pilote coulera quand le bouton est enfoncé).
4. Placez une longue allumette ou un allumeur de butane au brûleur pilote et en même temps, poussez le bouton de soupape de sûreté entièrement dedans. Le pilote s'allumera.
5. Tenez le bouton de soupape de sûreté dedans pendant approximativement 60 secondes avant de libérer.
6. Si le pilote ne reste pas s'allumait, la position de **OFF** de bouton de soupape de sûreté dans le sens des aiguilles d'une montre entièrement. Attendez cinq minutes, puis répétez les étapes 3. à 5.

### METTANT À FEU LE BRÛLEUR PRINCIPAL

Avec lampe témoin, tournez le bouton de soupape de sûreté dans le sens contraire des aiguilles d'une montre à la position de **ON**. Commutez la commande d'interrupteur à levier à la position de **ON** et le brûleur s'allumera.

### COUPANT LE BRÛLEUR PRINCIPAL

Commutez la commande d'interrupteur à levier à la position de **OFF**. Le pilote restera s'est allumé.

### COUPANT LE PILOTE

Soyez sûr que commande d'interrupteur à levier est éteint et enfonce et tourne le bouton de soupape de sûreté dans le sens des aiguilles d'une montre à la position de **OFF**.

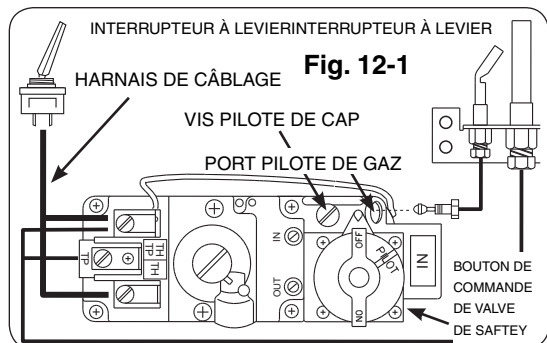

### AJUSTANT LE PILOTE

1. La flamme pilote devrait encercler le bout de générateur, et est préréglée à l'usine (Fig. 12-2).
2. Si l'ajustement est nécessaire, (Fig. 12-1) tournez la vis d'approche de gaz dans le sens contraire des aiguilles d'une montre pour augmenter la flamme pilote, ou pour diminuer dans le sens des aiguilles d'une montre la flamme pilote.

### ENTRETIEN

Votre brûleur à casserole est équipé d'un pilote de sûreté qui coupera l'offre de gaz au cas où le pilote serait ne brûlant pas ou ne fonctionnant pas correctement. Assurez-vous que le pilote est ajusté correctement et que les agrafes de cosse de générateur sont étroitement reliées aux vis terminales sur la valve. Si le pilote ne restera pas allumait, appelle votre utilité de gaz ou fournisseur locale de gaz.

Un contrôle périodique du suivant devrait être exécuté au moins annuellement par un représentant qualifié de service professionnel.

1. Valves et commande d'interrupteur à levier pour l'opération appropriée.
2. Système de conduite de cheminée pour la rouille, les dommages ou les fuites.
3. Une opération plus humide.
4. Orifices pour la saleté ou d'autres corps étrangers.
5. Contrôle visuel sur le brûleur.

Si cette unité était embarquée avec un extérieur, ou si un système à distance était installé plus tard, lisez et suivez les instructions à distance séparées d'actionner le brûleur à distance.

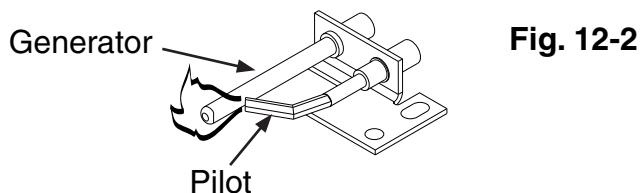

**Note:** La flamme pilote devrait encercler le dessus du générateur



# LIGHTING INSTRUCTIONS - SERIES 11 VALVE

## FOR YOUR SAFETY, READ BEFORE LIGHTING

### WARNING

If you do not follow these instructions exactly, a fire or explosion may result, causing property damage, personal injury, or loss of life.

Do not use this appliance if any part has been underwater. Immediately call for a qualified professional service technician to inspect the appliance and to replace any part of the control system and any gas control that has been underwater.

The Real-Fyre® burner system has a pilot that can be lit by hand using a match or lighter. When lighting the pilot, follow these instructions exactly.

**BEFORE LIGHTING**, smell all around the burner area for gas. Be sure to smell next to the floor, as some gas is heavier than air and will settle on the floor. **IF YOU SMELL GAS, FOLLOW THE INSTRUCTIONS ON P. 1.**

Use only your hand to push in or turn the gas control knob. Never use tools. If the knob will not push in or turn by hand, don't try to repair it. Call a qualified professional service technician. Force or attempted repair may result in fire or explosion.

### LIGHTING THE PILOT

To read the safety valve control knob (Fig. 13-1), read the marking nearest the teardrop-shaped metal pointer.

1. If the safety valve control knob is in the **PILOT** position, push in slightly on the knob and rotate it clockwise ↻ to the **OFF** position.
2. Release knob and wait five (5) minutes.
3. Turn safety valve knob counterclockwise ↻ to the **PILOT** position. (Only the pilot gas will flow when the knob is pushed in.)
4. Place a long match or a butane lighter at the pilot burner, and at the same time, push the safety valve knob fully in. The pilot will light.
5. Hold the safety valve knob in for approximately 60 seconds before releasing.
6. **If the pilot does not stay lit**, turn the safety valve knob clockwise ↻ to the full **OFF** position. Wait five (5) minutes, then repeat steps 3 through 5.

### IGNITING THE MAIN BURNER

With the pilot lit, turn the safety valve knob counterclockwise ↻ to the **ON** position. Switch the toggle switch control to the **ON** position, and the burner will light. Refer to the PARTS LIST for the toggle switch location.

### SHUTTING OFF THE MAIN BURNER

Switch the toggle switch control to the **OFF** position. The pilot will remain lit.

### SHUTTING OFF THE PILOT

Be sure the toggle switch control is **OFF** and depress and turn the safety valve knob clockwise ↻ to the **OFF** position.

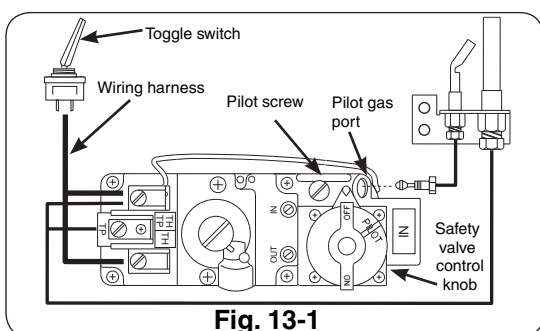

### ADJUSTING THE PILOT

- a. The pilot flame should encircle the generator tip, and is preset at the factory (Fig. 13-2).
- b. If adjustment is necessary (Fig.13-1), turn the gas adjustment screw counterclockwise ↻ to increase the pilot flame, or clockwise ↻ to decrease the pilot flame.

### MAINTENANCE

Your pan burner is equipped with a safety pilot that will shut off the gas supply in the event that the pilot is not functioning properly. Make sure the pilot is adjusted properly and that the generator spade clips are tightly connected to the terminal screws on the valve. If the pilot will not stay lit, call your local gas utility or gas supplier.

A periodic check of the following should be performed at least annually by a qualified professional service representative:

1. Valves and toggle switch control for proper operation.
2. Flue system for rust, damage, or leaks.
3. Damper operation.
4. Orifices for dirt or other foreign matter.
5. Visual check on the burner.

**If this unit was shipped with a remote, or if a remote system was installed later, read and follow the separate remote instructions to operate the burner remotely.**

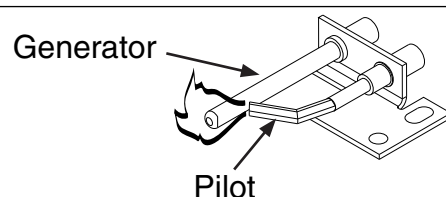

**Note:** Pilot flame should encircle top of the generator.

Fig. 13-2 Lighting the pilot



# INSTRUCTIONS D'ÉCLAIRAGE - VALVE DE LA SÉRIE 15

## POUR VOTRE SÛRETÉ, LISEZ AVANT DE S'ALLUMER

**AVERTISSEMENT :** Si vous ne suivez pas ces instructions exactement, un incendie ou une explosion peut résulter entraînant des dégâts matériels, des blessures ou la perte de la vie.

N'employez pas cet appareil si n'importe quelle partie a été sous-marine. Réclamez immédiatement un technicien de service professionnel qualifié et pour inspecter l'appareil et pour remplacer n'importe quelle partie du système de commande et de n'importe quelle commande de gaz qui a été sous l'eau.

Le Vrai-Fyre® système de brûleur a un pilote qui peut être allumé à la main en utilisant une allumette ou un allumeur. En allumant le pilote, suivez ces instructions exactement.

AVANT DE S'ALLUMER, sentez tous autour du secteur de brûleur pour le gaz. Soyez sûr de sentir à côté du plancher car un certain gaz est plus lourd que l'air et arrangez sur le plancher. **SI VOUS SENTEZ LE GAZ, SUIVEZ LES INSTRUCTIONS À LA P. 1.**

Utilisez seulement votre main pour enfoncer ou pour tourner le bouton de commande de gaz. N'utilisez jamais les outils. Si le bouton n'enfoncera pas ou ne tournera pas à la main, n'essayez pas de le réparer. Appelez un technicien de service professionnel qualifié et. La force ou la réparation essayée peut avoir comme conséquence l'incendie ou l'explosion.

### ALLUMER LE PILOTE

1. Tournez le bouton de commande d'ignitor (Fig. 14-1) de la soupape de commande de brûleur au côté de la casserole de brûleur dans le sens contraire des aiguilles d'une montre ↺ de sorte que la partie de rétrécissement du bouton se déplace de la position de **OFF**, légèrement vers **IGN** jusqu'à atteindre l'arrêt.
2. Serrez le bouton de commande d'ignitor dedans et tenez dedans pendant 5 secondes (seulement le gaz pilote coulera).
3. Continuez d'enfoncer tout en tournant le dans le sens contraire des aiguilles d'une montre ↺ supplémentaire de bouton de commande d'ignitor, vers la position **PILOT**, jusqu'à ce que vous entendiez un clic. Le clic est une indication que l'ignitor de pizio a été activé.

**Note:** Si l'étincelle de l'ignitor de pizio n'allume pas le pilote, répétez les étapes 2 et 3 jusqu'au pilote lights.

4. Continuez à tenir le bouton de commande d'ignitor en position **PILOT** pour 60 secondes après que le pilote a été allumé pour permettre au thermocouple de détecter la flamme pilote.

**Note:** La flamme pilote devrait toujours être présent quand le système de brûleur est en fonction, et devrait juste envelopper le bout du thermocouple.

### ALLUMAGE DU BRÛLEUR PRINCIPAL

1. Quand la flamme pilote est stable, libérez le bouton de commande d'ignitor et tournez-vous dans le sens contraire des aiguilles d'une montre ↺ vers la position de **ON** pour permettre le brûleur principal.
2. Tournez le bouton de commande de taille de flamme (Fig. 14-3) entièrement dans le sens contraire des aiguilles d'une montre ↺ pleinement la position de fonctionnement (Fig. 14-4) pour mettre à feu le brûleur chez BTUs maximum.

Après que le brûleur principal mette à feu, ajustez la taille de flamme comme indiqué ci-dessous.

### AJUSTEMENT DE LA TAILLE DE FLAMMET

1. Pour ajuster la flamme, tournez le bouton de commande de taille de flamme (Fig. 14-3) dans le sens contraire des aiguilles d'une montre ↺ à la taille de flamme d'augmentation et dans le sens des aiguilles d'une montre ↻ à la taille de flamme de diminution jusqu'à ce que les flammes aient les caractéristiques désirées.
2. Quand vous êtes fini appréciant votre feu, tournez le bouton de commande de taille de flamme à **OFF**. Le pilote restera s'est allumé. Le système de brûleur peut être relit en tournant le bouton de commande de taille de flamme vers **ON**.

### COUPER LE PILOTE

Si vous ne projetez pas sur employer votre système de brûleur pendant une période prolongée vous pouvez choisir de vous éteindre le pilote. Pour faire ceci, tournez le bouton de commande de taille de flamme jusqu'à la position de **OFF** et puis tournez le bouton de commande d'ignitor jusqu'à la position de **OFF** (Fig. 14-1).

**Important:** En fermant le système de brûleur complètement, tournez le bouton de control/ignition à la position de repos (Fig. 14-1). Si vous désirez tourner l'unité en arrière dessus, attendez une minute au minimum avant de commencer le procédé de rallumer (ALLUMANT LE PILOTE). Ceci permet à la soupape de sûreté de remettre à zéro en vue de rallumer.

**Si cette unité était embarquée avec un extérieur, ou si un système à distance était installé plus tard, lisez et suivez les instructions à distance séparées d'actionner le brûleur à distance.**

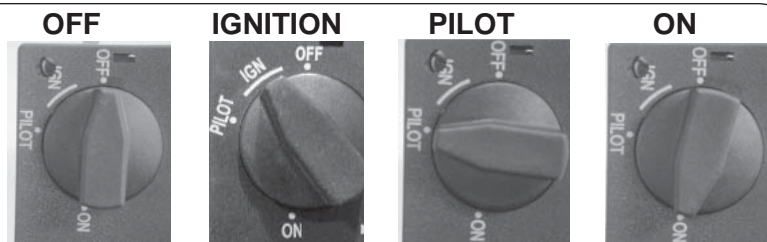

**POSITIONS D'OPÉRATION DE CLAPET À GAZ**  
Fig. 14-1

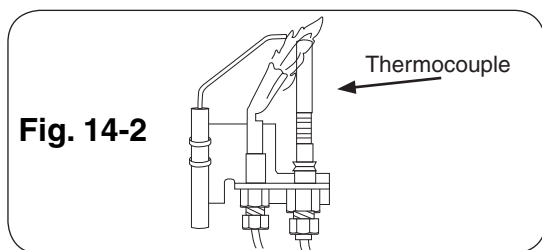

Fig. 14-2

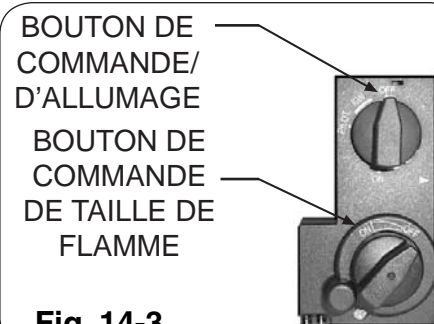

Fig. 14-3



**BOUTON DE COMMANDE DE TAILLE DE FLAMME**  
OFF Fig. 14-4 ON

# LIGHTING INSTRUCTIONS - SERIES 15 VALVE

## FOR YOUR SAFETY, READ BEFORE LIGHTING

### WARNING

If you do not follow these instructions exactly, a fire or explosion may result, causing property damage, personal injury, or loss of life.



Do not use this appliance if any part has been underwater. Immediately call for a qualified professional service technician to inspect the appliance and to replace any part of the control system and any gas control that has been underwater.

The Real-Fyre® burner system has a pilot. When starting the pilot, follow these instructions exactly.

**BEFORE LIGHTING**, smell all around the gas burner system area for gas. Be sure to smell next to the floor, as some gas is heavier than air and will settle on the floor. IF YOU SMELL GAS, FOLLOW THE INSTRUCTIONS ON P. 1.

Use only your hand to push in or turn the gas control knob. Never use tools. If the knob will not push in or turn by hand, don't try to repair it. Call a qualified professional service technician. Force or attempted repair may result in fire or explosion.

### LIGHTING THE PILOT



1. Turn the ignitor control knob (Fig. 15-1) on the burner control valve assembly to the side of the burner pan counterclockwise  so that the narrowing part of the knob moves from the **OFF** position, slightly toward **IGN**, until reaching the stop.
2. Press the ignitor control knob in and hold in for five (5) seconds (only pilot gas will flow).
3. Continue pressing in while turning the ignitor control knob further counterclockwise  toward the **PILOT** position until you hear a click. The click is an indication that the piezo ignitor has been activated.

**Note:** If the spark from the piezo ignitor does not light the pilot, repeat steps 2 & 3 until the pilot lights.

4. Continue to hold the ignitor control knob in the **PILOT** position for 60 seconds after the pilot has been lit to allow the thermocouple to detect the pilot flame.



**Note:** The pilot flame should always be present when the burner system is in operation, and should just envelop the tip of the thermocouple.

### IGNITING THE MAIN BURNER

1. When the pilot flame is stable, release the ignitor control knob and turn counterclockwise  to the **ON** position to enable the main burner.
2. Turn the flame-height control knob (Fig. 15-3) counterclockwise  to the fully **ON** position

(Fig. 15-4) to ignite the burner at maximum BTUs. After the main burner ignites, adjust the flame height as indicated below.

### ADJUSTING THE FLAME HEIGHT

1. To adjust the flame, turn the flame-height control knob (Fig. 15-3) counterclockwise  to increase the flame height, or clockwise  to decrease the flame height, until the flames have the desired characteristics.
2. When you are finished enjoying your fire, turn the flame-height control knob to **OFF**. The pilot will remain lit. The burner system can be relit by rotating the flame-height control knob toward **ON**.

### SHUTTING OFF THE PILOT

If you do not plan on using your burner system for an extended period, you may elect to extinguish the pilot. To do this, rotate the flame-height control knob to the **OFF** position and then rotate the ignitor control knob to the **OFF** position (Fig. 15-1).

**Important:** When shutting the burner system down completely, turn the control/ignition knob to the **OFF** position (Fig. 15-1). If you desire to turn the unit back on, wait a minimum of one (1) minute before starting the relight procedure (LIGHTING THE PILOT). This allows the safety valve to reset in preparation for relighting.

**If this unit was shipped with a remote, or if a remote system was installed later, read and follow the separate remote instructions to operate the burner remotely.**

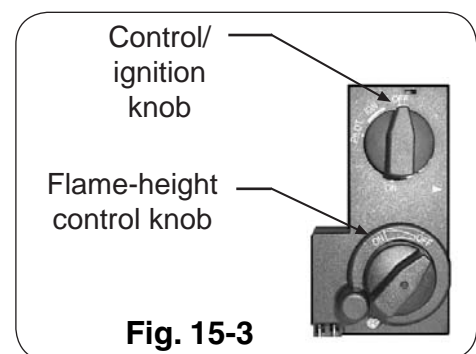
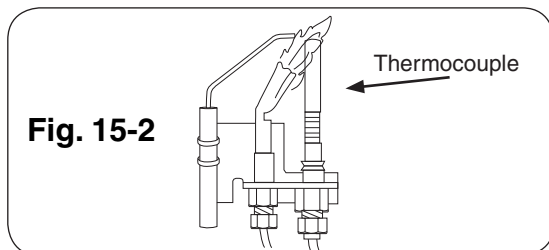
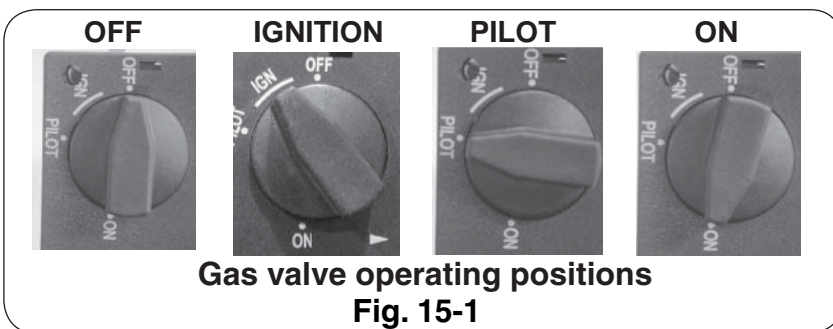

## POUR VOTRE SÛRETÉ, LISEZ AVANT DE S'ALLUMER

### AVERTISSEMENT

Si vous ne suivez pas ces instructions exactement, un incendie ou une explosion peut résulter, entraînant des dégâts matériels, des blessures, ou la perte de la vie.

**AVANT DE S'ALLUMER**, sentez tous autour du secteur de brûleur à gaz pour le gaz. Soyez sûr de sentir à côté du plancher parce qu'un certain gaz est plus lourd que l'air et arrangez sur le plancher. **SI VOUS SENTEZ LE GAZ, SUIVEZ LES INSTRUCTIONS À LA PAGE 1.**

- 1. ARRÊT!** Lisez l'information de sûreté ci-dessus.
- Arrêtez n'importe quel appareil électrique si utilisé avec le système de brûleur.
- Vérifiez le commutateur (marqué **I = mettez à feu** ; **O = au loin**) situé sur l'avant de la boîte de commutateur est placé au "**O**" ; (AU LOIN). Ne forcez pas.

Fig. 16-1

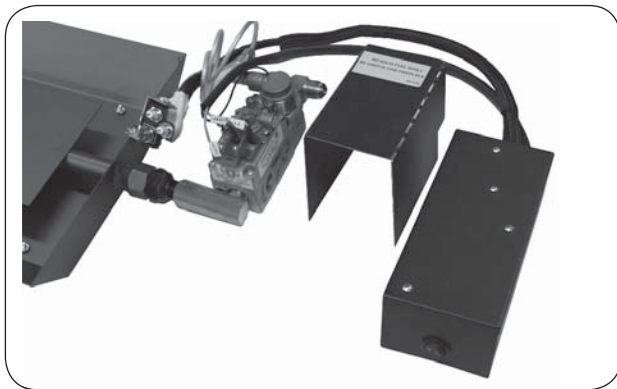

- 1. ALLUMAGE** - vérifiez le commutateur (marqué **I = mettez à feu** ; **O = au loin**) situé sur l'avant de la boîte de commutateur est placé aux minutes de l'attente cinq d'O. (5) pour que le gaz se dégage dehors.



- 1.** Serrez "**O**" (= "off") quand l'arrêt complet est désiré.



- 2.** Pression "**I**" (= "mettez à feu") après qu'une série d'étincelles rapides que le pilote s'allumera. Quand le pilote est stable, le brûleur principal mettra à feu.

- Attendez cinq (5) minutes pour dégager dehors n'importe quel gaz. Si vous sentez alors le gaz, **ARRÊTEZ !** Suivez l'information de sûreté ci-dessus. Si vous ne sentez pas le gaz, passez à la prochaine étape.
- Diminuez le "**I**" ; (**METTEZ À FEU**) branchez l'avant de la boîte de commutateur. Ceci transmet une série rapide d'étincelles à la tête pilote. Ces étincelles cessent quand la flamme pilote est allumée et écurie. Le pilote est situé au bon coin arrière du brûleur. Après une brève durée, le pilote allumera le brûleur principal.

**ATTENTION: SI L'ENSEMBLE DE GAZ NE MET PAS À FEU DANS 20 SECONDES, ARRÊTEZ, TOURNEZ LE COMMUTATEUR À "OFF", ATTENDENT 5 MINUTES RÉPÉTENT ALORS DES ÉTAPES 3-6.**

- **Le pilote devrait rester s'est allumé. S'il sort, répétez l'étape 3 à 6.**
- **Si le pilote ne restera pas allumé après que plusieurs essais, tournent la boîte de commutateur au "O" ; (AU LOIN) (fig. 16-1) et appelez votre fournisseur de technicien ou de gaz de service.**

- 6.** Pour arrêter l'ensemble, pressez le "**O**" ; (AU LOIN) branchez l'avant de la boîte de commutateur. L'écoulement de gaz cessera, et toutes les flammes sortiront.

**Si cette unité était embarquée avec un extérieur, ou si un système à distance était installé plus tard, lisez et suivez les instructions à distance séparées d'actionner le brûleur à distance.**

### OUR ARRÊTER LE BRÛLEUR

- 1. Mettez le commutateur dans la position de repos. Le brûleur s'éteindra et le pilote sortira.**

## LIGHTING INSTRUCTIONS - SERIES 01 VALVE

### FOR YOUR SAFETY, READ BEFORE LIGHTING

**WARNING:** If you do not follow these instructions exactly, a fire or explosion may result, causing property damage, personal injury, or loss of life.

**BEFORE LIGHTING**, smell all around the gas burner area for gas. Be sure to smell next to the floor, because some gas is heavier than air and will settle on the floor. IF YOU SMELL GAS, FOLLOW THE INSTRUCTIONS ON P. 1.

1. **STOP!** Read the safety information above.
2. Turn off any electrical appliance used with the burner system.

Fig. 17-1

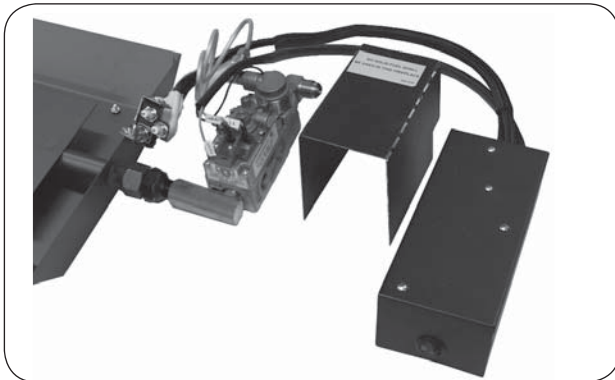

1. **LIGHTING** - Verify the switch (marked **I = IGNITE**; **O = OFF**) located on front of the switch box is set to **O**. Wait five (5) minutes for the gas to clear out.



1. Press **O (OFF)** when complete shutdown is desired.



2. Press **I (IGNITE)**  
After a series of rapid sparks, the pilot will light. When the pilot is stable, the main burner will ignite.

3. Verify the switch (marked **I = IGNITE**; **O = OFF**) located on the front of the switch box is set to "**O**" (**OFF**). Do not force.
4. Wait five (5) minutes to clear out any gas. If you then smell gas, **STOP!** Follow the safety information above. If you don't smell gas, go to the next step.
5. Depress the "**I**" (**IGNITE**) switch on the front of the switch box. This transmits a rapid series of sparks at the pilot head. These sparks cease when the pilot flame is lit and stable. The pilot is located at the rear right corner of the burner.

After a short time, the pilot will light the main burner.

**CAUTION:** IF THE GAS SET DOES NOT IGNITE WITHIN 20 SECONDS, STOP, PRESS "**O**" (**OFF**), WAIT FIVE (5) MINUTES, THEN REPEAT STEPS 3-6.

- The pilot should remain lit. If it goes out, repeat steps 3 through 6.
- If the pilot will not stay lit after several tries, turn the switch box to "**O**" (**OFF**) (Fig. 17-1) and call your service technician or gas supplier.

6. To turn the set **OFF**, press the "**O**" (**OFF**) switch on the front of the switch box. The gas flow will cease, and all flames will go out.

**If this unit was shipped with a remote, or if a remote system was installed later, read and follow the separate remote instructions to operate the burner remotely.**

## SHUT-OFF INSTRUCTIONS - SERIES 01 VALVE

1. Put the switch in the **OFF** position. The burner will extinguish, and the pilot will go out.



# CLEANING AND MAINTENANCE

## MAINTENANCE

Once installed and operating properly, your Real-Fyre® glass burner will require regular maintenance. You should inspect your glass burner and controls (where installed) for the following:

1. Moisture may cause the glass in your burner pan to settle. To improve the burn, follow these tips:
  - a. Settling of glass - Using a screwdriver or flat-blade knife, carefully stir the glass, loosening the material. Clear up any spills.
2. Debris around the control (if equipped)  
-Inspect control and pilot to be sure they are free of dirt or debris.
3. **Insects and burner blockage** - Check the burner ports and air shutter, if present, to make sure they are free from debris. Blocked burner ports and orifices may result in a fire at the air shutter.

## CLEANING

The pilot assembly (if equipped) must be kept clean and clear of debris at all times for the fireplace burner system to be safely and effectively operated. Dust, carpet fibers, paper, spider webs, pet hair, etc. in the fireplace or on the burner assembly can affect operation of burner and pilot assembly. Vacuum or use compressed air from a can or compressor to clean out pilot assembly area, air shutter holes, burner orifices, and pilot air intake openings. Blockage in this area will affect the operation of pilot assembly.

## FLAME DESCRIPTION

Observe the flames. The flames should be blue at the base and a combination of blue/yellow at the body and tips. The flames should be 16" to 18" tall. (See Figure 18-1). Inspect the flames periodically. If flames appear different, contact a professional service technician or your gas supplier to correct the problem.

## SERVICE

While some minor service conditions can be handled by the owner of the glass burner, a qualified professional service technician should be called to maintain and service your glass burner and any installed control systems. In addition, a periodic examination and cleaning of the solid-fuel-burning fireplace venting system should be conducted by a qualified professional service technician. The TROUBLESHOOTING section of these instructions serves as a guide for ensuring optimum performance of your glass burner.

To protect your investment in your Real-Fyre® gas fireplace burner system and keep it operating safely for years to come, maintain, clean, and inspect it regularly. We recommend following these instructions at the beginning of each fireplace season and as needed throughout the year, depending on your usage pattern and the environmental conditions in your home. More frequent cleaning and maintenance may be necessary when burning propane gas than with natural gas.

- Replace all batteries for remote transmitters and receivers if installed.
- Check and readjust the burner air shutter.
- Clean and test the ignitor and pilot (if equipped).





## PILOT BURNER ADJUSTMENT (IF EQUIPPED)

The pilot burner is preset at the factory and should normally not require any adjustment. However, should adjustment be necessary, the following steps should be taken:

With the pilot burner lit and the control knob in the pilot position, remove the heatshield covers. Adjust the screw located on the control valve (see Fig. 19-1). Using a screwdriver, turn the pilot adjustment screw slowly clockwise to reduce the flame, or counterclockwise to increase the flame.

The adjustment screw can be turned so that the pilot flame is completely extinguished. The pilot flame should be a quiet soft blue flame with yellow tipping that encircles the thermocouple tip.

Replace the heatshield covers. Turn the control knob to the **ON** position to assure proper ignition of the burner system.

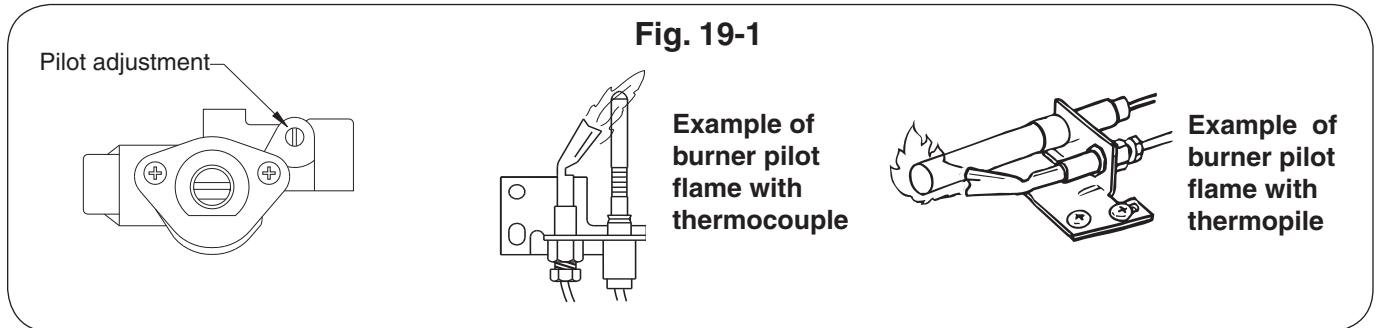

## TROUBLESHOOTING

| SYMPTOM   | CAUSE  | SOLUTION  |
|---|--|---|
| <b>1. Smoking and/or sooting</b><br><br>(IMMEDIATELY STOP USING. Call your gas supplier or another qualified professional installer or service agency.) | <b>A. Poor draft or downdraft</b>  | <b>A. Check for chimney blockage.</b> Be sure chimney is at least 3' taller than anything within 10' of it in all directions. If not, consult a chimney sweep. Chimney cap or fan may help. Under severe conditions, you may need to open a window near the fireplace about 1" to 2" when burning the unit. |
|   | <b>B. Damper closed</b>  | <b>B. Open damper fully</b> when operating burner system.   |
|   | <b>C. Burner is positioned too close to the front of the firebox</b>     | <b>C. Move burner system to the center</b> of the firebox.  |
|   | <b>D. Improper glass/gems placement or amount</b>                        | <b>D. See PLACEMENT OF GLASS / GEMS</b> section.  |
|   | <b>E. Air mixer on propane set is closed</b>                             | <b>E. Open air mixer completely.</b>  |
|   | <b>F. Improper burner for gas used</b>                                   | <b>F. Use only a natural-gas set</b> with natural gas or use only a propane-gas set with propane gas.   |
| <b>2. Low flame</b>   | <b>A. Incorrect decorative media for type of gas used</b>                | <b>A. Consult your dealer for proper set.</b>   |
|   | <b>B. Insufficient gas supply</b>  | <b>B. Other gas appliances may be competing</b> for gas supply. Consult installer or plumber. Orifice size is based upon 7" w.c. pressure for natural gas and 11" w.c. pressure for propane gas. Plumbing must supply adequate pressure.  |
|   | <b>C. Blockage or kink in connector kit, plumbing, or burner orifice</b> | <b>C. Clean out blockage.</b> If connector kit is kinked, replace it.   |
|   | <b>D. Valve not fully open</b>   | <b>D. Open valve fully.</b>   |

## TROUBLESHOOTING (cont.)

| SYMPTOM   | CAUSE   | SOLUTION   |
|---|---|--|
| <b>3.</b> Uneven flame distribution<br>(Lower at one end of the burner) | <b>A.</b> Clogged or blocked portholes                    | <b>A.</b> Clear out burner ports.  |
|   | <b>B.</b> Insufficient gas pressure and/or supply         | <b>B.</b> Consult installer or plumber (see solution 2B).  |
|   | <b>C.</b> Decorative media may be packed down too tightly | <b>C.</b> Loosen media around burner pipe by running a kitchen knife along both sides of the pipe. Even out media in burner pan.               |
|   | <b>D.</b> Auxiliary shutoff valve partially closed        | <b>D.</b> Open valve fully. Usually you will find this along the wall 3' from the fireplace.   |
| <b>4.</b> Flame at air mixer<br>(For propane units)                     | <b>A.</b> Clogged or blocked burner ports                 | <b>A.</b> Clear out burner ports.  |
|   | <b>B.</b> Insufficient gas pressure and/or supply         | <b>B.</b> Consult installer or plumber (see solution 2b).  |
|   | <b>C.</b> Decorative media may be packed down too tightly | <b>C.</b> Loosen media around the burner by running a kitchen knife along both sides of the pipe. Be sure granules are used with an air mixer. |
|   | <b>D.</b> Excessive gas pressure                          | <b>D.</b> Contact your gas supplier.   |

# WARRANTY

## PETERSON VENTED DECORATIVE GAS APPLIANCE LIMITED WARRANTY

All Peterson gas logs are **WARRANTED** for as long as you own them (lifetime).

All Peterson burner assemblies are **WARRANTED** for **TEN (10) YEARS**.

All Peterson glass is **WARRANTED** for **FIVE (5) YEARS**.

SPK-26 controls are covered by a **THREE (3) YEAR "All Parts" Warranty**.

All other Peterson valves, pilots, and controls are covered by a **ONE (1) YEAR Limited Warranty (excluding batteries)**.

### PLEASE KEEP A COPY OF YOUR SALES SLIP FOR PROOF OF PURCHASE

This warranty applies to the original purchaser and to single family residential use only. It commences from date of purchase, and is valid only with proof of purchase.

This warranty does not cover parts becoming defective through misuse, accidental damage, electrical damage, improper handling, storage, and/or installation. Product must be installed (and gas must be connected) as specified in the instructions or operator's manual, by a **qualified professional installer**. Accessories, parts, valves, remotes, etc., when used must be Peterson Co. product.

This warranty **does not** apply to rust, corrosion, oxidation, or discoloration, unless the affected component becomes inoperable. It **does not** cover labor or labor-related charges.

This warranty specifically excludes liability for **indirect, incidental**, or consequential damages. Some states do not allow the exclusion or limitation of incidental or consequential damages, so the above exclusion may not apply to you. This warranty gives you specified legal rights, and you may have other rights that may vary from state to state.

For additional information regarding this warranty, or to place a warranty claim, contact the R.H. Peterson dealer where the product was purchased.

**TO REGISTER YOUR PRODUCT ONLINE GO TO: [WWW.RHPETERSON.COM](http://WWW.RHPETERSON.COM),  
AND CLICK ON PRODUCT REGISTRATION. THANK YOU FOR YOUR PURCHASE.**

|                        |             |             |                                     |                     |       |
|------------------------|-------------|-------------|-------------------------------------|---------------------|-------|
| <b>Quality Check</b>   |             |             | <b>Date:</b> _____                  |                     |       |
| <b>Burner Orifices</b> | <b>Nat.</b> | <b>L.P.</b> | <b>Leak Test:</b> _____             | <b>Model#:</b>      | _____ |
| <b>Main:</b>           | _____       | _____       | <b>Burn Test:</b> _____             | <b>Serial#:</b>     | _____ |
| <b>Other:</b>          | _____       | _____       | <b>Gas Type:</b> <u>Nat. / L.P.</u> | <b>Air Shutter:</b> | _____ |
|                        |             |             |                                     | <b>Inspector:</b>   | _____ |